

Laboratory 5: Amplifier Design Using Operational Amplifiers

In ELEC 120, [Lab 6](#), you designed circuits using the LM35 temperature sensor, DC fan, 741 and OPA 551 operational amplifier, and light emitting diodes (LEDs). In this lab, we will focus on the design of amplifier circuits that are used with a sound card.

Preparation and Data Sheets

1. Please study the op amp section in the [elements](#) page developed by Prof. Mastascusa.
2. Please study Chapter 5 in *Electric Circuits* (8th Edition), by J.W. Nilsson and S.A. Riedel, Prentice-Hall, 2008.
3. Please search for LM 741 and OPA 552 data sheets and compare the following attributes for the LM 741 and OPA 552 op amps:
open loop gain, input resistance, maximum output current.

Design 1: Sound Card Isolation Circuit

1. Please design a circuit using a 741 op amp to provide an output voltage equal to the voltage provided by a sound card.
2. Build the circuit and test the circuit using a function generator. Use the oscilloscope to observe the input and output as you vary the frequency of a sine wave. Measure the voltage across a $33\ \Omega$ resistor (modeling headphones with $32\ \Omega$ input resistance).
3. Is there a limit to the input *voltage* so that the maximum *current* delivered by the 741 op amp is not exceeded?
4. If you create a Thevenin model for your isolation amplifier, what is the Thevenin resistance, assuming ideal op amp behavior?
5. Now attach the sound card. Play your favorite music and observe the output of the amplifier on the oscilloscope. Listen to the music using the headphones.

Analysis: Voltage Amplifier Circuits

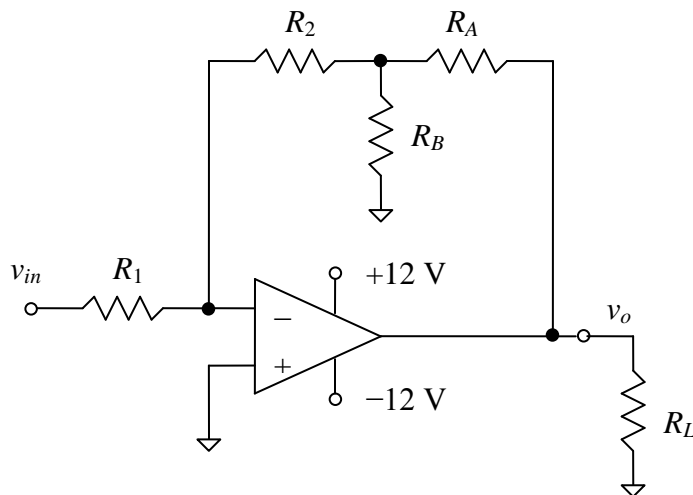

Figure 2: Inverting amplifier

1. For the circuit in Figure 2 (which you may recall from ELEC 120), show that

$$\frac{v_o}{v_{in}} = -\left(\frac{R_A}{R_2} + \frac{R_A}{R_B} + 1\right) \frac{R_2}{R_1}$$

2. For the circuit in Figure 3, show that $\frac{v_o}{v_{in}} = -\frac{R_2}{R_1}$.

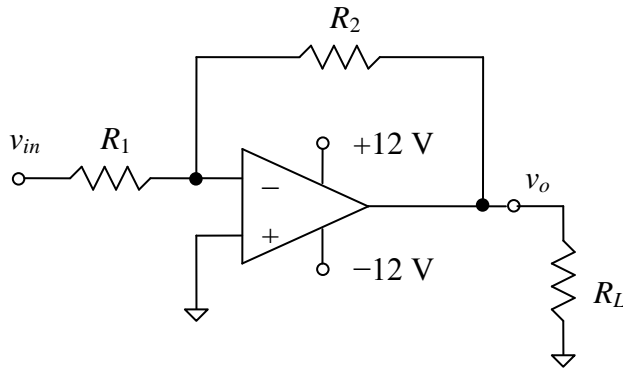

Figure 3: Inverting amplifier.

3. What is the advantage of the circuit in Figure 2 compared with Figure 3?
4. Assuming ideal op amp behavior, what is the Thevenin model for the circuits in Figures 2 and 3 to the left of the node where the load resistor is attached?

Design 3: Amplifier Design for an 8 Ω Speaker

1. Design an amplifier to drive an 8 Ω speaker. Your amplifier should provide maximum power to the speaker while not exceeding the limitations of the op amp.
2. What is the gain of your design? Why did you choose this gain? What current will be delivered to the speaker? Should you use an LM 741 or OPA 552 op amp?
3. What is the maximum power delivered to the speaker in your design?
4. Build and test your design using the function generator and oscilloscope. Test with an open-circuit load and an 8 Ω resistor load (which models the speaker). The amplitude of your input signal should be similar to the voltage provided by the sound card.
5. Now connect the sound card through your isolation amplifier and inverting amplifier, and listen to music through an 8 Ω speaker.

Lab Report

Each pair of students should submit a brief report before leaving lab summarizing your answers to the questions. How does the load resistance (33 Ω versus 8 Ω) affect your choice of op amp and the power delivered to the load?